

LOC	DIST	REVISIONS				
REV	BY	DATE	DESCRIPTION	DATE	DWN	APPR
AJ	16	BH	REVISED PER EC 0514-0288-02	18DEC02	DD	KW

- 1 BRASS PER 00-B-626.
- 2 BERYLLIUM COPPER PER ASTM-B-196
- 3 NYLON PER ASTM-D-4066, BLACK.
- 4 POLYMETHYLPENTENE GENERAL PURPOSE, NATURAL.
- 5 0.00076 [.000030] MINIMUM GOLD PER MIL-G-45204.
- 6 0.00254 [.000100] MINIMUM GOLD PER MIL-G-45204.
- 7 RG-180/U, RG-180A/U, RG-195/U, AND 21-597.
- 8 RG-58/U, RG-58A/U, RG-58B/U, AND RG-58C/U.
- 9 RG-55/U, RG-55A/U, RG-55B/U, RG-141/U, RG-142/U, AND RG-223/U.
- 10 BRAND REX T-209A.
- 11. SEE IS 1770.
- 12 NYLON PER ASTM-D-4066, NATURAL
- 13 DIELECTRIC MATERIAL: VALOX 325, WHITE

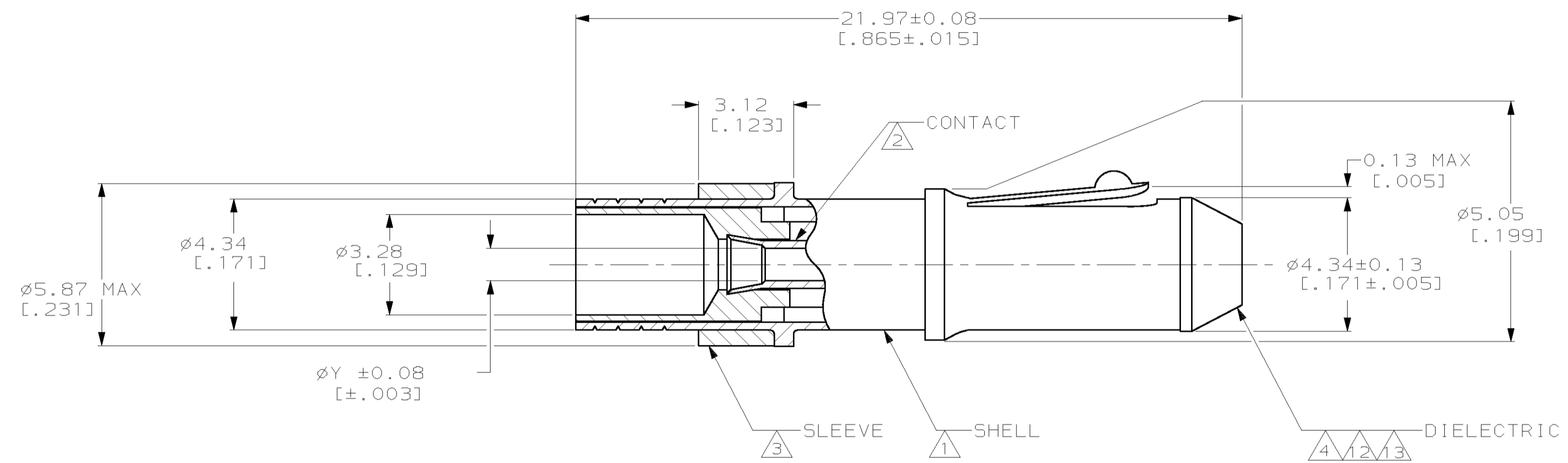

13	5	5	.030 OUNCES	-	-	1.07 [.042]	-	-	-	2-201145-7		
12	5	5	.030 OUNCES	-	-	1.07 [.042]	-	-	-	2-201145-6		
	6	6	.030 OUNCES	-	-	0.58 [.023]	-	-	-	1-201145-0		
	5	5	.030 OUNCES	-	-	0.81 [.032]	-	-	-	201145-8		
	5	5	.030 OUNCES	-	-	1.07 [.042]	-	-	-	201145-4		
	5	5	.030 OUNCES	-	-	0.58 [.023]	-	-	-	201145-2		
	5	5	.030 OUNCES	-	-	1.07 [.042]	-	-	-	201145-1		
			CONTACT PLATING	SHELL PLATING	WEIGHT	CABLE SIZE	CRIMP TOOL	Y	3 FERRULE QTY=1	2 SPRING RETENTION QTY=1	1 PIN ASSY QTY=1	PART NUMBER

THIS DRAWING IS A CONTROLLED DOCUMENT.

DIMENSIONS: mm [INCHES]	TOLERANCES UNLESS OTHERWISE SPECIFIED:	DWN J. LIPPERT 08 JAN 90	CHK M. SINFED 23 FEB 90	APPROV EL ADAMS 23 FEB 90	NAME
0 PLC ±-	1 PLC ±-	2 PLC ±-	3 PLC ±0.20 (.008)	4 PLC ±-	ANGLES ±-
MATERIAL	FINISH	SIZE	CAGE CODE	DRAWING NO	RESTRICTED TO
SEE NOTES	SEE NOTES	A1	00779	201145	-
CUSTOMER DRAWING			SCALE	SHEET	REV
			8:1	1 OF 1	BH

AMP TYCO Electronics
 Harrisburg, PA 17105-3608

PRODUCT SPEC: 108-12021
 APPLICATION SPEC: -

PIN, MINIATURE SERIES